

LID OPTIONS

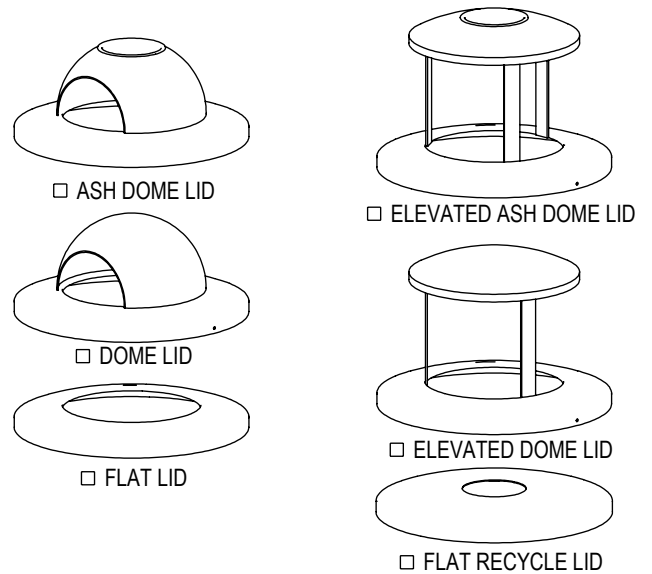

PRODUCT: CRTR-32
 DESCRIPTION: CARNIVAL TRASH RECEPTACLE 32 GAL.

DATE: 6-13-18
 ENG: SMC

CONFIDENTIAL DRAWING AND INFORMATION IS NOT TO BE COPIED OR DISCLOSED
 TO OTHERS WITHOUT THE CONSENT OF GRABER MANUFACTURING, INC.
 SPECIFICATIONS ARE SUBJECT TO CHANGE WITHOUT NOTICE.

TRASH LIDS ARE ATTACHED WITH 2 EA. STEEL
 VINYL COATED AIRCRAFT CABLE.
 PLASTIC LINER INCLUDED.
 ALL FASTENERS ARE STAINLESS STEEL

SITE FURNISHING IS POWDER COATED WITH TGIC POLYESTER.
 STEEL SURFACE PREP INCLUDES MECHANICAL AND CHEMICAL
 ETCHING FOLLOWED WITH A COATING TO IMPROVE ADHESION
 AND CORROSION RESISTANCE.