

□ WITHOUT ARMRESTS

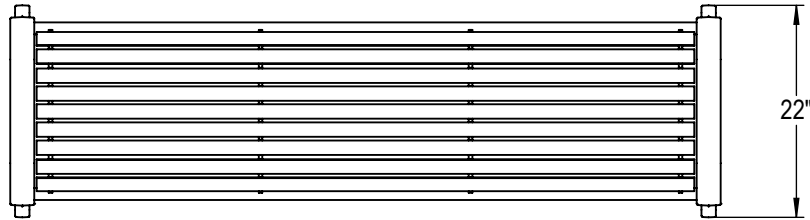

CNF-2 25"
 CNF-4 51"
 CNF-5 61"
 CNF-6 74" (SHOWN)
 CNF-8 98"

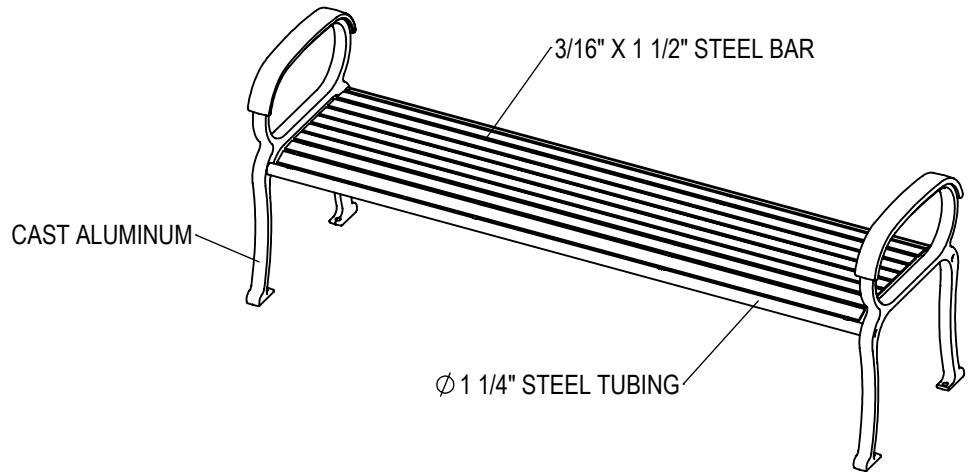
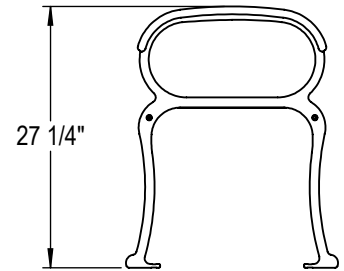
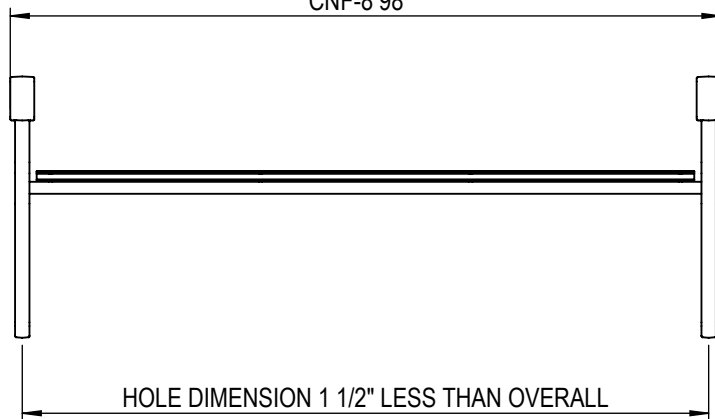

PRODUCT: CNF-HS
 DESCRIPTION: CUNNINGHAM FLAT BENCH, HORIZONTAL STRAPS

DATE: 2-7-20
 ENG: SMC

CONFIDENTIAL DRAWING AND INFORMATION IS NOT TO BE COPIED OR DISCLOSED TO OTHERS WITHOUT THE CONSENT OF GRABER MANUFACTURING, INC. SPECIFICATIONS ARE SUBJECT TO CHANGE WITHOUT NOTICE.

©2020 GRABER MANUFACTURING, INC. ALL PROPRIETARY RIGHTS RESERVED.

ALL FASTENERS ARE STAINLESS STEEL
 SOME ASSEMBLY REQUIRED

SITE FURNISHING IS POWDER COATED WITH TGIC POLYESTER. STEEL SURFACE PREP INCLUDES MECHANICAL AND CHEMICAL ETCHING FOLLOWED WITH A COATING TO IMPROVE ADHESION AND CORROSION RESISTANCE.