

# CURVED CARNIVAL 3 SEAT INSTRUCTION SHEET

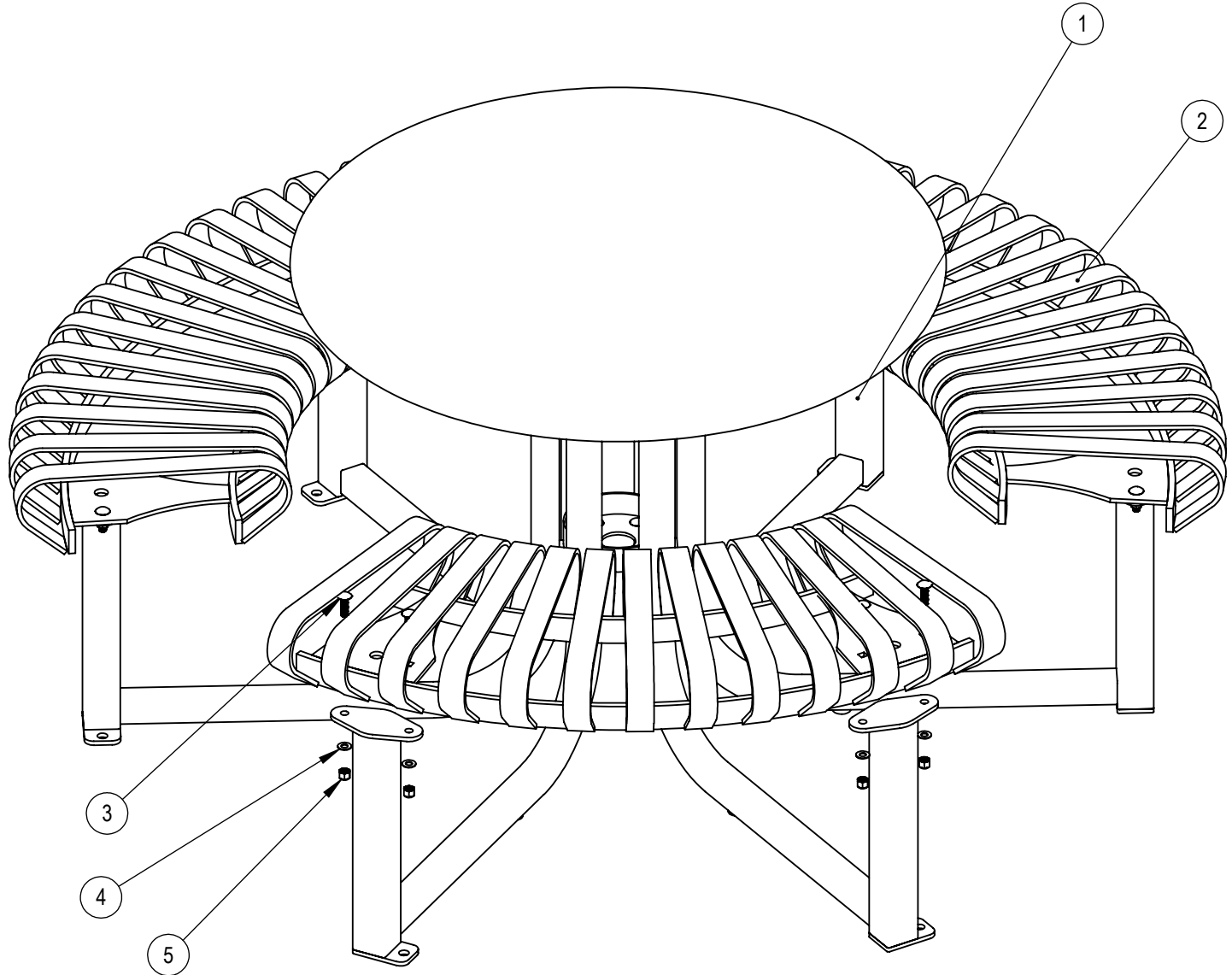

ITEM NO.	PART NUMBER	QTY.
1	CARNIVAL CURVED TABLE LEGS AND TOP	1
2	CARNIVAL CURVED SEATS	3
3	CARRIAGE BOLT 3/8"-16 x 1 1/4"	12
4	3/8" SS Flat Washer	12
5	3/8"-16 Lock Nut	12

# CURVED CARNIVAL TABLE TOP INSTRUCTION SHEET

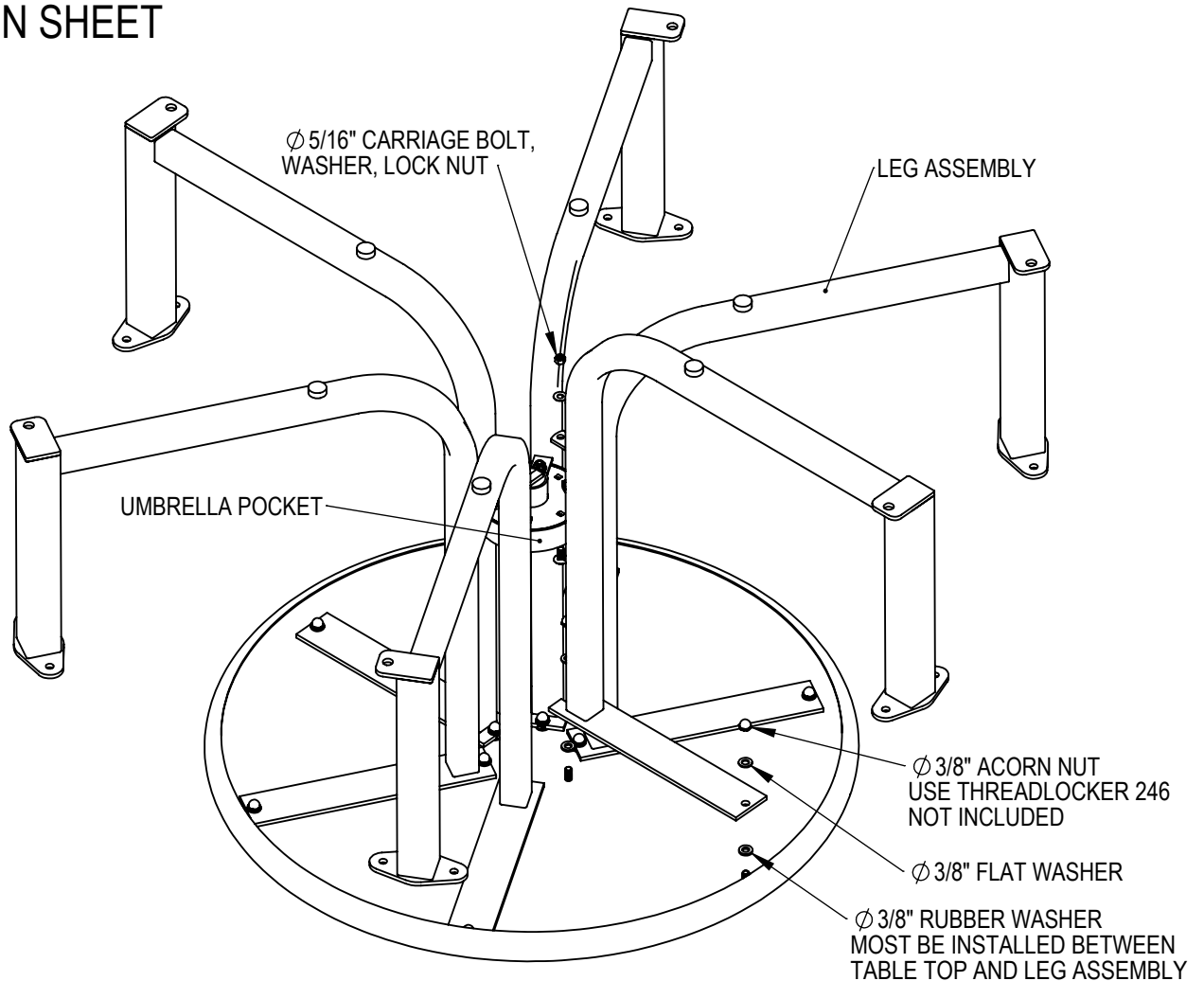

ALL FASTENERS MUST BE HAND TIGHTENED.  
DO NOT OVER TORQUE. LEAVE LOOSE UNTIL  
FULLY ASSEMBLED.

ASSEMBLE UPSIDE DOWN ON A CLEAN  
SCRATCH FREE SURFACE.

- STEP 1: INSTALL THE LEGS ON THE TABLE.
- STEP 2: INSTALL THE UMBRELLA POCKET.
- STEP 3: FLIP THE TABLE OVER.
- STEP 4: INSTALL THE SEATS.
- STEP 5: TIGHTEN ALL THE HARDWARE.

3 SEAT IS SHOWN

ITEM NO.	PART NUMBER	QTY.
1	UMBRELLA POCKET	1
2	LEGS AND TOP	1
3	LOCK NUT 5/16"	6
4	NEOPRENE WASHER 3/8"	12
5	FLAT WASHER 3/8"	12
6	ACORN NUT 3/8"	12
7	CARRIAGE BOLT 5/16 X .75"	6
8	WASHER FLAT 5/16"	6
9	ANTISEIZE	1